

# 深圳市龙信达科技有限公司

Shenzhen Longxinda Technology Co., Ltd.

电话/TEL: 0086-755-29129090 传真/FAX: 0086-755-29129092

---

## 光电子器件

Photoelectronic Devices

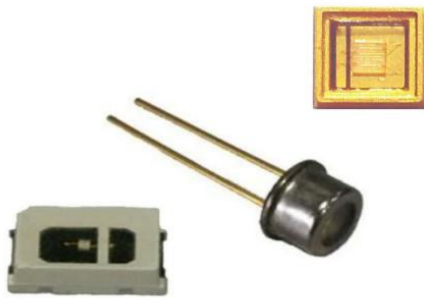

紫外型硅光电二极管

UV Photodiode

**注册地址** 深圳市宝安区新安创业西路东南侧富源商贸大厦 1 栋 B 座 703 **邮编/Zip code** 473000

Addr.: B703 ,Fuyuan Trade Center,Chuangye Road, Shenzhen, Guangdong, China

<http://www.lxdcn.com>

E-mail: [wusheng888@126.com](mailto:wusheng888@126.com)

# 深圳市龙信达科技有限公司

Shenzhen Longxinda Technology Co., Ltd.

电话/TEL: 0086-755-29129090 传真/FAX: 0086-755-29129092

## 特点/Feature:

测量型线性硅光二极管传感器;  
Linear Silicon Light Diode Sensor;  
紫外波段范围响应;  
Ultraviolet band range response;

## 应用/Application:

紫外线检测, 荧光反射检测, 火焰检测, 仪器仪表灯.  
Ultraviolet detection, Fluorescence Reflection Detection, Flame detection,  
Instrument lamp.

## 极限参数/Limit Parameters:

项目/Item	符号/Symbol	数值/Value	单位/Unit
工作温度 <sup>※1</sup> Operating temperature	T <sub>opr</sub>	-20~+70	度/°C
储存温度 Storage temperature	T <sub>stg</sub>	-25~+80	度/°C
焊接温度 (3 秒) <sup>※2</sup> Welding temperature (3 seconds)	T <sub>sol</sub>	260	度/°C

※1 芯片材料不同, 工作温度不同。若需要较耐高温产品, 建议选用 LXD025M180-380NM 或 LXD11M180-380NM 产品。

※1 The chip materials used are different, so the working temperature is different. If a slightly high temperature resistant product is needed, it is recommended to choose: LXD025M180-380NM or LXD11M180-380NM

※2 在底部 3mm 处焊接, 焊接温度控制在额定值内, 时间在 3s 秒以内。

Welding at the bottom of 3mm, the welding temperature is controlled in the limit range, and the time is controlled within 3S seconds.

注册地址 深圳市宝安区新安创业西路东南侧富源商贸大厦 1 栋 B 座 703 邮编/Zip code 473000  
Add.: B703, Fuyuan Trade Center, Chuangye Road, Shenzhen, Guangdong, China

<http://www.lxcdcn.com>

E-mail: [wusheng888@126.com](mailto:wusheng888@126.com)

# 深圳市龙信达科技有限公司

Shenzhen Longxinda Technology Co., Ltd.

电话/TEL: 0086-755-29129090 传真/FAX: 0086-755-29129092

## 型号及命名的含义

LXD XX X X X

|            |            |            |            |   \_\_光谱范围区间  
|            |            |            |            |   \_\_窗口形式: K 光学玻璃 Q 石英玻璃 L 透镜 E 环氧树脂  
|            |            |            |            |   \_\_封装形式: C 陶瓷座 M 金属封装 S 树脂封装  
|            |            |            |            |   \_\_光敏面积尺寸  
|            |            |            |            |   \_\_公司名称缩写 (龙信达 简写 LXD)

## Type and Naming Meaning

LXD XX X X X

|            |            |            |            |   \_\_Spectral Range  
|            |            |            |            |   \_\_Window Material: K: Optical Glass / Q: Quartz Glass  
|            |            |            |            |            / L: Lens / E: Epoxy Resin  
|            |            |            |            |   \_\_Packaging: C: Ceramic Seat / M: Metal Packaging/  
|            |            |            |            |            / S: Epoxy Packaging  
|            |            |            |            |   \_\_Chip size(Photosensitive area size)  
|            |            |            |            |   \_\_Company abbreviation: LONGXINDA Abbreviation:LXD

## 参数符号说明/Parameter symbol:

Size:光敏面积

$\lambda$  : 波长响应范围/ Photosensitive Area

$\lambda_p$ : 峰值波长/wavelength response range

Rmax: 开路电压/Open-circuit Voltage

$V_{Rmax}$  : 最大反向电压 /Maximum Reverse Voltage

ID: 暗电流/Dark Current

Tc: 温度系数/Temperature Coefficient

C : 电容/Capacitance

VB: 紫外/可见光抑制比 /Ultraviolet/Visible Inhibition Ratio

注册地址 深圳市宝安区新安创业西路东南侧富源商贸大厦 1 栋 B 座 703 邮编/Zip code 473000

Addr.: B703 ,Fuyuan Trade Center,Chuangye Road, Shenzhen, Guangdong, China

<http://www.lxdcn.com>

E-mail: [wusheng888@126.com](mailto:wusheng888@126.com)

# 深圳市龙信达科技有限公司

Shenzhen Longxinda Technology Co., Ltd.

电话/TEL: 0086-755-29129090 传真/FAX: 0086-755-29129092

## 典型参数/Parameter TYP.(at 25°C)

项目/Item	芯片面积	光学参数 (25°C)			电参数 (25°C)				
		Optical parameters (25 C)			Electrical parameters (25 C)				
测试条件	Size	$\lambda$	$\lambda_p$	Rmax	V <sub>Rmax</sub>	I <sub>D</sub>	T <sub>c</sub>	C	VB
	mm <sup>2</sup>	nm	nm	A/W	V	nA	%/°C	pF	
Conditions				@355nm		E=0 VR=-1V		E=0 VR=0 1MHz	(Rmax/ R400nm)
LXD1EME 180-370NM	0.1	280-370	355	0.18	10	<1	-0.1	2.3	>10 <sup>4</sup>
LXD02SE 280-370NM	0.2	280-370	355	0.18	10	<1	-0.1	4.6	>10 <sup>4</sup>
LXD11CQ 180-370NM	1	180-370	355	0.18	10	<1	-0.1	4.6	>10 <sup>4</sup>
LXD11MQ 220-370NM	1	220-370	360	0.18	10	<1	-0.1	23	>10 <sup>4</sup>
LXD11MQ 220-400NM	1	220-400	375	0.243	10	<1	0.05	60	>10 <sup>4</sup>
LXD11MQ 220-420NM	1	220-420	385	0.205	10	<1	-0.1	55	>10 <sup>4</sup>
LXD025M 180-380NM	0.25	200~380	275	0.13	10	<0.1	-0.1	27	>10 <sup>4</sup>
LXD11M 180-380NM	1	200~380	275	0.13	10	<0.1	-0.1	97	>10 <sup>4</sup>

注册地址 深圳市宝安区新安创业西路东南侧富源商贸大厦 1 栋 B 座 703 邮编/Zip code 473000

Addr.: B703 ,Fuyuan Trade Center,Chuangye Road, Shenzhen, Guangdong, China

<http://www.lxcdn.com>

E-mail: [wusheng888@126.com](mailto:wusheng888@126.com)

# 深圳市龙信达科技有限公司

Shenzhen Longxinda Technology Co., Ltd.

电话/TEL: 0086-755-29129090 传真/FAX: 0086-755-29129092

尺寸图 (单位: 毫米) / Dimension map (in millimetres):

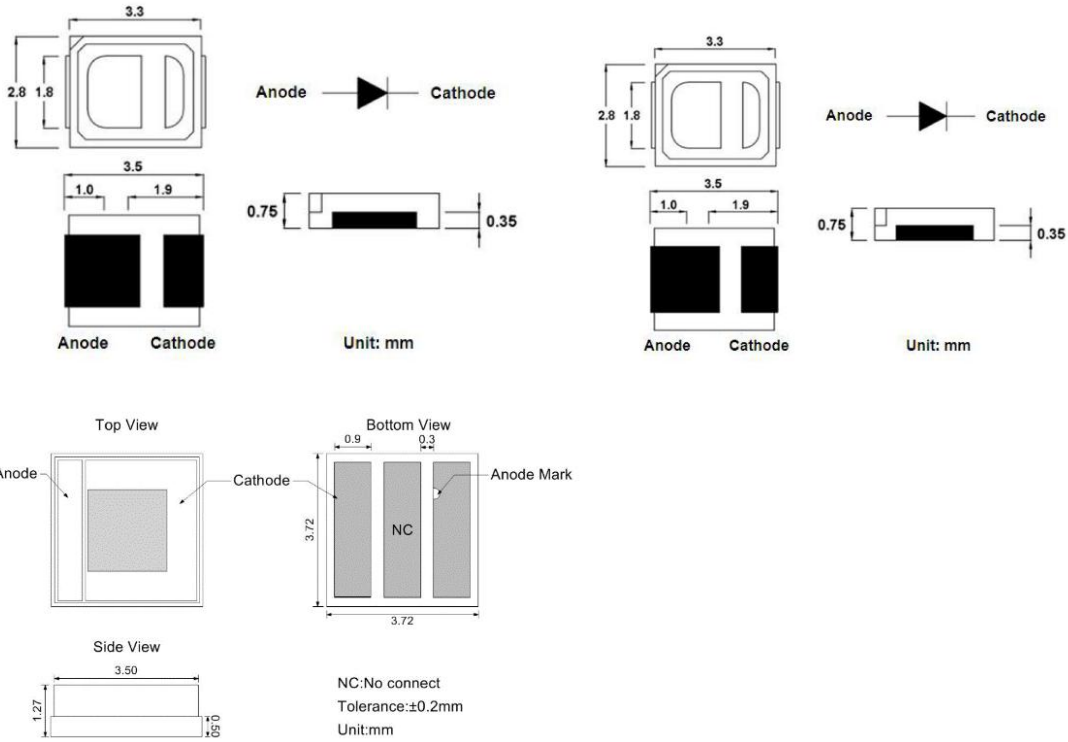

图/ Fig.1-1

图/ Fig.1-2

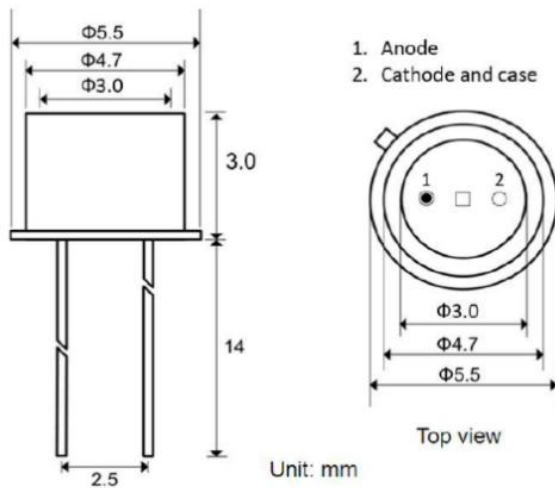

图/ Fig.1-3

注册地址 深圳市宝安区新安创业西路东南侧富源商贸大厦 1 栋 B 座 703 邮编/Zip code 473000

Add.: B703 ,Fuyuan Trade Center,Chuangye Road, Shenzhen, Guangdong, China

<http://www.lxcdn.com>

E-mail: [wusheng888@126.com](mailto:wusheng888@126.com)

# 深圳市龙信达科技有限公司

Shenzhen Longxinda Technology Co., Ltd.

电话/TEL: 0086-755-29129090 传真/FAX: 0086-755-29129092

型号/Model	尺寸图编号/Dimension No.
LXD1EME180-370NM	图/Fig.1-1
LXD02SE280-370NM	图/Fig.1-1
LXD11CQ180-370NM	图/Fig.1-2
LXD11MQ220-370NM	图/Fig.1-3
LXD11MQ220-400NM	图/Fig.1-3
LXD11MQ220-420NM	图/Fig.1-3
LXD025M180-380NM	图/Fig.1-3
LXD11M180-380NM	图/Fig.1-3

典型光谱曲线图: / Wavelength TYP.



图 1-1-01

型号/Model	尺寸图编号/Dimension No.
LXD1EME180-370NM	图/Fig.1-1-01
LXD11MQ180-370NM	
LXD11MQ220-370NM	

注册地址 深圳市宝安区新安创业西路东南侧富源商贸大厦 1 栋 B 座 703 邮编/Zip code 473000

Addr.: B703 ,Fuyuan Trade Center,Chuangye Road, Shenzhen, Guangdong, China

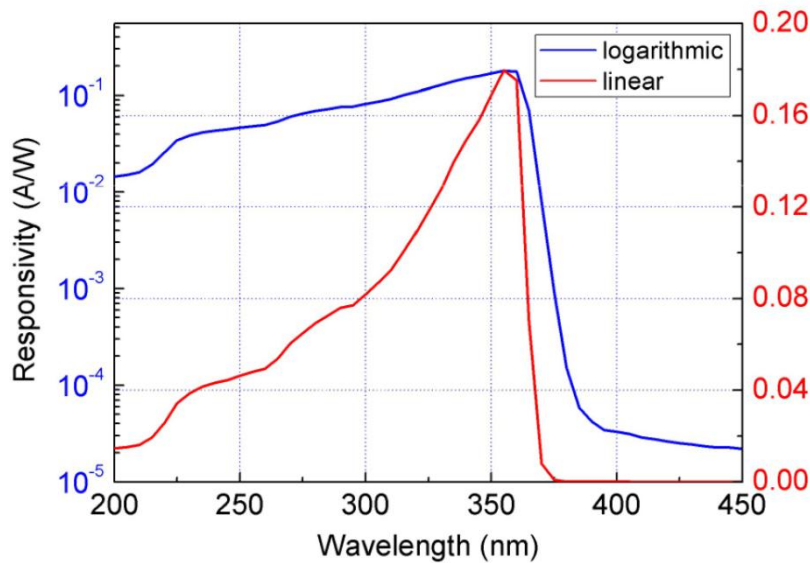
<http://www.lxcdn.com>

E-mail: [wusheng888@126.com](mailto:wusheng888@126.com)

# 深圳市龙信达科技有限公司

Shenzhen Longxinda Technology Co., Ltd.

电话/TEL: 0086-755-29129090 传真/FAX: 0086-755-29129092



图 1-1-02

型号/Model	尺寸图编号/Dimension No.
LXD11MQ220-370NM	图/Fig.1-1-02
LXD11MQ220-400NM	

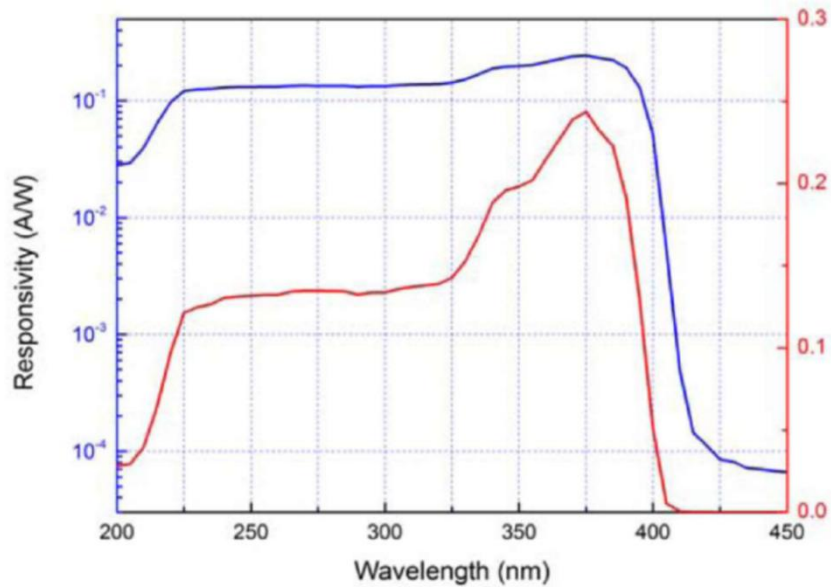

图 1-1-03

型号/Model	尺寸图编号/Dimension No.
LXD11MQ220-420NM	图/Fig.1-1-03

注册地址 深圳市宝安区新安创业西路东南侧富源商贸大厦 1 栋 B 座 703 邮编/Zip code 473000

Addr.: B703 ,Fuyuan Trade Center,Chuangye Road, Shenzhen, Guangdong, China

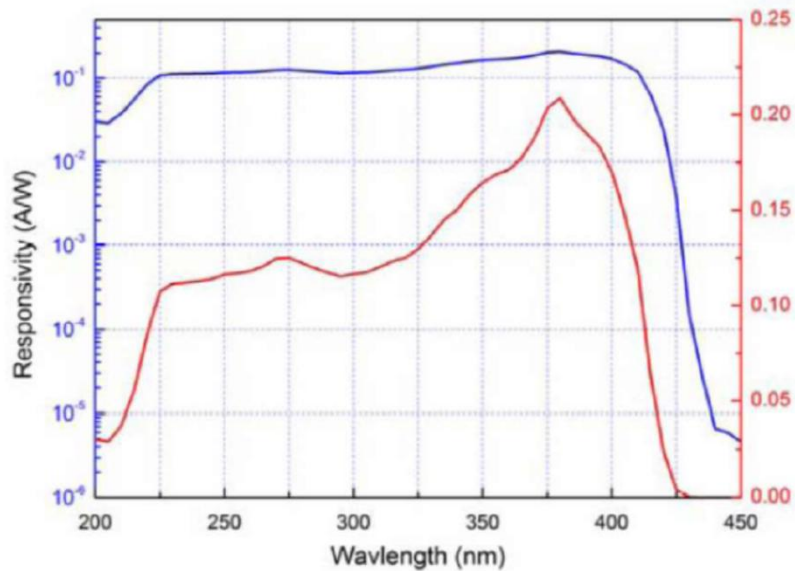
<http://www.lxdcn.com>

E-mail: [wusheng888@126.com](mailto:wusheng888@126.com)

# 深圳市龙信达科技有限公司

Shenzhen Longxinda Technology Co., Ltd.

电话/TEL: 0086-755-29129090 传真/FAX: 0086-755-29129092



图 1-1-04

型号/Model	尺寸图编号/Dimension No.
LXD11MQ220-440NM	图/Fig.1-1-04

TYP.

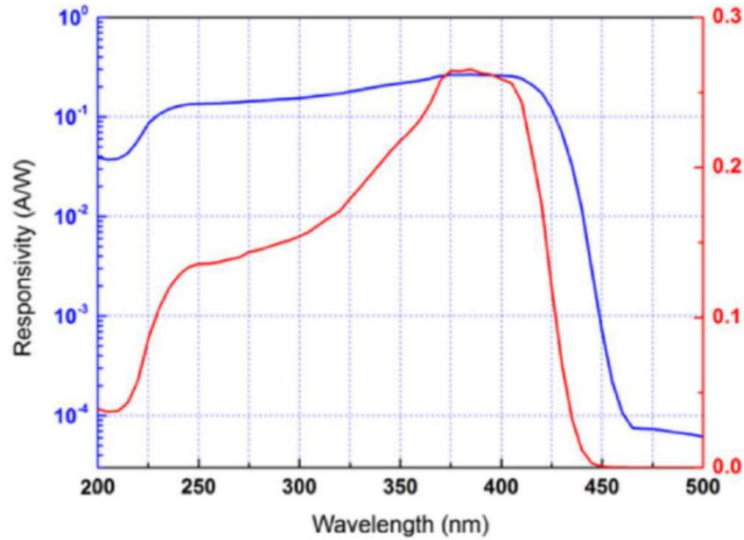

图 1-1-05

型号/Model	尺寸图编号/Dimension No.
LXD025M180-380NM	图/Fig.1-1-05
LXD11M180-380NM	

注册地址 深圳市宝安区新安创业西路东南侧富源商贸大厦 1 栋 B 座 703 邮编/Zip code 473000

Addr.: B703 ,Fuyuan Trade Center,Chuangye Road, Shenzhen, Guangdong, China

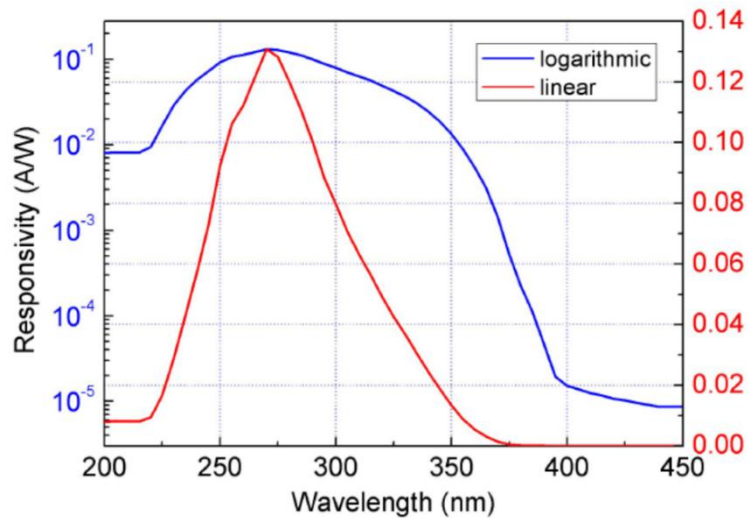
<http://www.lxdcn.com>

E-mail: [wusheng888@126.com](mailto:wusheng888@126.com)



# 深圳市龙信达科技有限公司

Shenzhen Longxinda Technology Co., Ltd.

电话/TEL: 0086-755-29129090 传真/FAX: 0086-755-29129092

---

## 使用注意事项/Use precautions:

1、不要在超出产品规格范围的情况下使用;

Do not use beyond the scope of product specifications.

2、规格书提到的应用电路仅作参考,在实际应用中根据具体的需要来设计电路和调整参数;

The application circuits mentioned in the specifications are for reference only. In practical application, the circuits and parameters are designed and adjusted according to the specific needs.

3、焊接温度和时间不能超过额定范围,在焊接过程中或焊接完成时尽量避免外力作用于引脚,不要重复焊接;

4、The welding temperature and time should not exceed the rated range. During the welding process or when the welding is completed, the external force should be avoided from acting on the pins and the welding should not be repeated.

5、本产品为网络版本的参数表,若有参数或型号变更恕不另行通知,请采购前和工组人员取得联系,索取样品进行产品测试或认证。样品通过并签订承认书后再进行批量采购;

This product is a network version of the parameter table, if there are parameters or model changes without notice, please contact the team before purchasing to obtain samples for product testing or certification. Samples are purchased in batches after they are approved and signed.

5、产品表面的损伤和污染会影响光电流,避免在过于潮湿环境中使用;

Damage and contamination of product surface will affect photocurrent and avoid using in excessive humid environment.

6、本产品贴片产品标准包装为2000只包装,直插为200只包装。

The SMD standard package of this product is 2000 packages and DIP 200 packages.

**注册地址** 深圳市宝安区新安创业西路东南侧富源商贸大厦1栋B座703 **邮编/Zip code** 473000

Addr.: B703 ,Fuyuan Trade Center,Chuangye Road, Shenzhen, Guangdong, China

<http://www.lxcdn.com>

E-mail: [wusheng888@126.com](mailto:wusheng888@126.com)